

Feedforward and Feedback Mechanisms in a Dynamical Model of Human T Cell Development and Regulation

Michael E. Brandt^{*}, *Senior Member, IEEE*, Gerhard R. F. Krueger,
Guanyu Wang, and L. Maximilian Buja

*M. E. Brandt is with the Center for Computational Biomedicine, University of Texas Health Science Center at Houston - SHIS, Houston, Texas 77030 (e-mail: mbrandt@uth.tmc.edu).

G. R. F. Krueger is with the Department of Internal Medicine, Division of Allergy and Clinical Immunology, UT Houston Medical School, Houston, Texas 77030.

G. Wang is with the Department of Pathology and Laboratory Medicine, UT Houston Medical School, Houston, Texas 77030.

L. M. Buja is with the Department of Pathology and Laboratory Medicine, UT Houston Medical School, Houston, Texas 77030.

Running Head: T Cell Biocomputational Model

Abstract---We describe a computational model of human T cell regulatory dynamics. We use this to simulate changes in T cell pool numbers and for studying feedback and feedforward responses in and among these pools. The pools identified are the bone marrow stem cell compartment, early and late thymocyte compartments and the peripheral compartment of mature T lymphocytes. Simulated data show variable intercompartmental strengths indicative of a range of sensitivities to feedback regulation and respective variable feedforward responses. The results compare well to known clinical and experimental data rendering the computational model a good basis for further research in T cell development and regulation.

Index Terms---T cell pools, feedforward, feedback, computational simulation model

I. INTRODUCTION

Feedback control constitutes one of the most important mechanisms that allow the hematopoietic and lymphatic systems to adapt the body's defense reactions to changes in the environment; alterations in peripheral cell pool numbers influence proliferative or inhibitory responses in (the less mature) thymic and stem cell pools. This phenomenon causes the clinically diagnostic leukocytosis and "*shift to the left*" with less mature neutrophils as commonly noted in the peripheral blood in severe bacterial infections, or lymphocytosis with less mature lymphocytes in viral infections [1]. Metcalf once suggested that a disturbed feedback mechanism may be contributory to neoplastic cell proliferation [2]. We have collected and quantified T cell data arising from different acute and chronic viral infections to further substantiate this phenomenon [3-5].

In order to study such cell pool changes in infectious and neoplastic diseases, we have designed and validated a computational model for simulating T cell pool dynamical changes [6-8]. The model is based upon cells shifting from immature to mature cell pools under the influence of various factors as well as of feedback and feedforward mechanisms according to current concepts of the T cell immune system and using standard textbook data [10-12]. The proposed model has also proven useful for simulating cellular changes in chronic viral infections as in cases of pseudolymphomatous lymphoproliferation, i.e. the Canale-Smith syndrome [7-9]. The present study reports data of stability testing of this model by alterations of virtual feedforward and feedback parameter values and discusses their possible biological implications.

II. MATERIALS AND METHODS

The basic conceptual model (for technical details see [6-8]) is presented in Figs. 1 and 2 with its full mathematical representation as

$$\begin{aligned}
 \dot{w} &= \mu_w + w \left(\sum_{h=1}^H P_{w_h} - \sum_{j=1}^J D_{w_j} - \sum_{k=1}^K I_{w_k} + ax - by + cz \right), \\
 \dot{x} &= \mu_x + x \left(\sum_{l=1}^L P_{x_l} - \sum_{m=1}^M D_{x_m} - \sum_{n=1}^N I_{x_n} - dy + ez \right) + fw, \\
 \dot{y} &= \mu_y + y \left(\sum_{q=1}^Q P_{y_q} - \sum_{r=1}^R D_{y_r} - \sum_{s=1}^S I_{y_s} + gz \right) + ux, \\
 \dot{z} &= \mu_z + z \left(\sum_{\theta=1}^{\Theta} P_{z_\theta} - \sum_{\omega=1}^{\Omega} D_{z_\omega} - \sum_{\gamma=1}^{\Gamma} I_{z_\gamma} \right) + \delta y.
 \end{aligned} \tag{1}$$

Detailed stability testing confirmed the practicality of the modeling approach [8]. The model functions in a circular ring-type network configuration with feedforward and feedback connections expressed as a system of four interrelated ordinary differential equations (ODEs) as shown schematically in Fig. 2. Notations used are as follows:

- w, x, y, z : T cell pools in bone marrow (stem cells), thymic cortex, thymic medulla (immature stages), and periphery (mature cells), respectively.
- The dot notation indicates time rate of change of cell numbers in each pool (e.g. $\dot{w} = dw/dt$)

- $\{P, D, I\}$'s: set of factors regulating differentiation, proliferation and inhibition respectively in pools w, x, y and z . Each individual P, D , or I factor is represented by a real number in the model and they form a lumped summation as implemented and shown above in (1).
- $\mu_{[w-z]}$: average regenerative potential of each compartment.
- $a - g, u, \delta$: scalar gains (strengths) of the feedforward and feedback connections within and between cell pools.

The model's feedback terms are implemented as a multiplication of the state variable of the compartment itself, the inflow from the forward compartment, and a compartmental cross-renewal rate implemented as a scalar gain term (e.g., axw). In this sense, $a - g, u$ and δ represent virtual values for the "strength of connections" between pools, thus of feedback and feedforward mechanisms (see also Table II). Their actual values under normal conditions (i.e. in the healthy individual) were determined by use of both manual and semi-automated search procedures (parameter search algorithm) during the model validation phase. These procedures were described in detail in previous publications [6-8].

The model operates with textbook data for normal pool sizes [10-12]. Simulations were carried out using Matlab software developed by us. The ODEs were solved using fourth-order Runge-Kutta integration. Each computer run was simulated continuously over a given timeframe, e.g., for establishing the lifetime values from birth ($t_0 = 0$) to the age of 80 years. Respective initial cell pool conditions and parameter values for simulating a clinically normal human adult are listed in Table I.

In order to further study the sensitivity of the cell pools $w - z$ to feedback and feedforward control, we varied the factorial parameters $a - g$, u and δ (i.e. the virtual values for the strength of connections between pools) in a stepwise manner (one at a time with all other gains fixed) and monitored the resulting shifts in cell pools. Cut-off points for the present study were changes in cell numbers, which – according to clinical experience – are usually incompatible with an average healthy human individual (i.e. more than 30% deviation from normal average).

III. RESULTS

When substituting parameters from Table I into (1), one obtains the following set of ordinary differential equations:

$$\begin{aligned}
 \dot{w} &= 50.0 - 0.531w + (5.0 \times 10^{-7})wx - (2.0 \times 10^{-7})wy + (5.0 \times 10^{-7})wz, \\
 \dot{x} &= 25.0 - 0.04x - (5.5 \times 10^{-8})xy + (3.6 \times 10^{-7})xz + (5.0 \times 10^{-7})w, \\
 \dot{y} &= (2.5 \times 10^6) - 0.7y + 0.05x + (1.0 \times 10^{-7})yz, \\
 \dot{z} &= (1.0 \times 10^4) - 0.023z + 0.001y.
 \end{aligned} \tag{2}$$

Note that the summated proliferation, differentiation and inhibition factors reduce to a single negative self-feedback gain factor in each compartment (cell pool). From these equations, the following pool interactions are observed: 1) there is negative self-feedback for each compartment; 2) there is a positive feedforward from compartments $w \rightarrow x \rightarrow y \rightarrow z$; 3) compartment z is in a positive feedback relationship with its previous compartments y , x , and w ; and 4) compartment y

is in a negative feedback relationship with its previous compartments x and w . This seems to be in good agreement with known human T cell system developmental dynamics [10, 12]. Figure 3 shows a simulation run of normative developmental data across the lifespan using (2). The main feature we observe is the slowly exponentially decreasing number of peripheral T lymphocytes across the lifespan, which compares well with actual human lymphocyte counts decreasing from $6,320 \pm 3,000/\text{mL}$ blood at age 1 month to $1,890 \pm 830/\text{mL}$ blood at 80 years [10]. T cells decrease respectively during this period from $78\% \pm 10\%$ to $61\% \pm 13\%$ of total lymphocyte counts. The stem cell pool (w) remains fairly stable during the 80-year period, while early and late thymic cells (x and y) reflect the physiologic involution of the organ. This is most prominent in the rapidly proliferating pool of early thymic cells (x).

Table II lists the ranges of values for the feedback and feedforward parameters for the individual cell pools $w - z$ (bone marrow to peripheral lymphatic cells) permitting an overall “healthy” state. Relative sensitivity of each parameter was determined in an arbitrary manner by dividing this range by its midrange value (similar to the measure of coefficient of variation): if the ratio is less than 0.5 we labeled it “high” sensitivity in Table II, if the ratio is between 0.5 and 1 we called it “med”, and if greater than 1 we classified it as “low.” Of the seventeen parameters listed in Table II, eleven are classified as medium to low sensitivity. A wide range of values for a given parameter indicates that a cell pool is fairly insensitive to extraneous influences and therefore has a significant amount of inherent stability. Representative graphs are shown in Figs. 4 and 5. Several reaction patterns are suggested by applying our computational model.

- A) Bone marrow and early thymic cell pools (w, x) appear to be relatively insensitive to feedback influences allowing for a wide range of factorial values without showing

pathologic changes. This indicates that these cell compartments possess a sturdy internal stability, and that any external stimuli must be quite strong in order to cause abnormal cell pool numbers and therefore disease resulting from this. In addition, the bone marrow stem cells apparently also possess a high regenerative potential (μ_w).

- B) On the contrary, intrathymic feedback control ($y \rightarrow x$) appears quite sensitive, as does the feedback from the periphery to the thymus ($z \rightarrow y, z \rightarrow x$). Thus low-level stimuli will be responded to sensitively, and exceeding such low levels may lead to system imbalance, hence possible disease. Inherent stability thus appears quite low. The regenerative potentials (μ_x and μ_y) however, are quite high as well.
- C) The intensity of a feedback stimulus from early thymus back to the bone marrow stem cell pool appears to be quite high compared with the other pools. Thus there may be an intense request for stem cell influx in cases of decreasing thymic cortical cell pools.
- D) The compartmental negative self-feedback sensitivity varies from low (w), to medium (x), to high for both y and z . Recall from system theory that negative self-feedback assists in maintaining a system's stability by helping it to keep its behavior "on course" (and thus has a "memory" attribute). Therefore we see that w and x allow for a more relaxed or flexible self-control as compared with compartments y and z that exert a firmer, tighter self-control (by virtue of their narrow normative ranges). This tighter self-control regime in and of itself would be indicative of a less flexible and/or adaptive response to external stimuli in general, whereas a broader self-control regime would lead to a more flexible response to such stimuli.
- E) Feedforward values, i.e. the stimulus for cell progression (or differentiation) from one pool to the next mature one, show a broad range of control (i.e. insensitive response to

stimulus) for cell influx into the thymus and cell movement within the thymus, yet a narrower range (i.e. higher sensitivity to stimulus) for outflow of cells from thymus into peripheral compartments.

IV. DISCUSSION

The computational model we present here originated from a number of experimental and clinical studies into the pathogenesis of malignant lymphomas [7, 8, 13], and was designed exclusively by us to simulate changes in cell pool numbers in order to serve investigations of atypical cell proliferation and malignancy, or cell loss and aplasia. It does not focus on functional activities of mature peripheral T cells as a number of other computational models currently in use do [14-20]. Available cell numbers, however, such as in hyperplastic, aplastic and neoplastic responses do influence functional activities, and our model may well supplement others in this regard.

Since Rudolph Virchow's first description of leukemoid reactions [1, 2, 21-22], it is presumed that a certain feedback mechanism exists between peripheral blood cell numbers and cell production sites. One major source for the regeneration of mature peripheral lymphocytes, and thus a potential target for feedback control, is the stem cell pool [24-26]. An essential intermediate for the production of fully immunocompetent lymphocytes is the thymus or respective extrathymic sites [27-29]. A thymic cell pool thus could constitute another focus for feedback regulation. It was intriguing, therefore, to use our computational model for studying the cell population dynamics along with their feedback and feedforward mechanisms.

Our simulations show that the essential source for stem cells (bone marrow and early thymocytes) show a striking internal regenerative stability, which may render them fairly insensitive to extraneous (toxic and other) stimuli. This appears reasonable, since otherwise we would likely expect more frequent aplastic and immune deficient responses. The strength of connection between the bone marrow pool (w) and thymic cortical pool (x) appears in a way that both may be considered a single unit. Once cells have entered the thymic compartments, their shifting to further developmental stages appears quite sensitive even to minor stimuli reflecting the importance of “*thymic imprinting*” for the production of functioning T lymphocyte populations. Also, feedback mechanisms exerted by peripheral cell pools to the thymus appear quite sensitive, guaranteeing a response even to minor stimuli. This appears of practical importance, since it is only a minor percentage of peripheral T lymphocytes that may exert such stimuli, i.e. the pool of virgin (naive) T lymphocytes. Overall changes in the entire peripheral T cell pool do not apparently affect thymic outflow of mature naive T cells [30-33]. Although small, this pool of peripheral naive T cells is responsible for maintaining T cell diversity [34].

Feedforward values, i.e. the transition of cells from one pool into the next maturation stage, relate well to the variable intensity of feedback stimulation and its interpretation, and thus confirm the validity of our simulations. Again, the moderately high sensitivity of feedforward from thymus to the periphery guarantees the effective replacement of naive mature T lymphocytes. With respect to compartmental self-feedback control we found that the capacity for “*elastic homeostasis*” resides predominantly in the bone marrow and early thymic compartments in comparison with the thymic medullary and peripheral blood compartments. This may suggest the latter two as targets for developed future therapies that may increase their flexibility (decrease sensitivity), hence reducing possible susceptibility to disease.

The computational model we have presented for simulating cell pool changes in the T cell system appears capable of calculating cell pool changes and respective alterations in feedback and feedforward controls. It thus can mimic disorders arising from changes in selective cell numbers or their unresponsiveness and hyper-responsiveness. Future studies should focus on qualitative aspects of feedback and feedforward controls so that an even closer correlation of computer simulations with the pathogenesis of human diseases becomes possible.

REFERENCES

- [1] D. S. Rosenthal, "Hematologic manifestations of infectious disease," In *Hematology, Basic Principles and Practice, 3rd edition*, R. Hoffman, E. J. Benz Jr, S. J. Shattil, B. Furie, H. J. Cohen, L. E. Silberstein, P. McGlave, Eds. New York: Churchill Livingstone, 2000, pp 2420-2430.
- [2] D. Metcalf, "The nature of leukemia: neoplasm or disorder of hematopoietic regulation?" *Med. J. Aust.*, vol. 2, pp. 739-746, 1971.
- [3] G. R. F. Krueger, G. Bertram, A. Ramon, B. Koch, D. V. Ablashi, M. E. Brandt, G. Wang and L. M. Buja, "Dynamics of infection with human herpesvirus-6 in EBV-negative infectious mononucleosis: data acquisition for computer modeling," *In Vivo*, vol. 15, pp. 373-380, 2001.
- [4] G. R. F. Krueger, B. Koch, J. D. Weldner, G. Tymister, A. Ramon, M. E. Brandt, G. Wang G and L. M. Buja, "Dynamics of active progressive infection with HIV1: data acquisition for computer modeling," *In Vivo*, vol. 15, pp. 513-518, 2001.
- [5] G. R. F. Krueger, M. E. Brandt, G. Wang G and L. M. Buja, "Dynamics of HTLV-1 leukemogenesis: data acquisition for computer modeling," *In Vivo*, vol.16, pp. 87-92, 2002. M. E.

- [6] M. E. Brandt, G. Wang, G. R. F. Krueger and L. M. Buja, "A biodynamical regulatory model of the human T-cell system," *Proc. 2nd Joint Conf. IEEE EMBS-BMES*, pp 254-255, 2002.
- [7] G. R. F. Krueger, M. E. Brandt, G. Wang and L. M. Buja, "TCM-1: a nonlinear dynamical computational model to simulate cellular changes in the T cell system: conceptional design and validation," *Anticancer Res.*, vol. 23, pp. 123-136, 2003.
- [8] M. E. Brandt, G. R. F. Krueger, G. Wang and L. M. Buja, "A biodynamical model of human T-cell development and pathology: design, testing and validation," *J. Theoret. Med.*, submitted
- [9] G. R. F. Krueger, M. E. Brandt, G. Wang, F. Berthold and L. M. Buja, "A computational analysis of Canale-Smith syndrome: chronic lymphadenopathy simulating malignant lymphoma," *Anticancer Res.*, vol. 22, pp. 2365-2372, 2002.
- [10] G. R. F. Krueger, *Klinische Immunpathologie*. Stuttgart: W Kohlhammer, 1985.
- [11] T. Ogawa, M. Kitagawa, K. Hirokawa, "Age-related changes of human bone marrow: a histometric estimation of proliferative cells, apoptotic cells, T cells, B cells and macrophages," *Mech. Aging Develop.*, vol. 117, pp. 57-68, 2000.
- [12] D. M. Knowles, *Neoplastic hematopathology*, Philadelphia: Williams & Wilkins, 1998.
- [13] G. R. F. Krueger, "Abnormal variation of the immune response as related to cancer," in *Influence of the host on tumor development*, RA Herberman, Ed. Vol.3 of *Cancer Growth and Progression*, HE Kaiser, Ed. Dordrecht NL: Kluwer, pp.139-161, 1989.
- [14] R. L. Bar-Or and L. A. Segel, "On the role of a possible dialogue between cytokine and TCR presentation mechanisms in the regulation of autoimmune disease," *J. Theor. Biol.*, vol. 190, pp. 161-178, 1998.
- [15] L. A. Segel and R. L. Bar-Or, "On the role of feedback in promoting conflicting goals of the adaptive immune system," *J. Immunol.*, vol. 163, pp. 1342-1349, 1999.

- [16] R. L. Bar-Or, "Feedback mechanisms between T helper cells and macrophages in the determination of the immune response," *Math. Biosci.*, vol. 163, pp. 35-58, 2000.
- [17] N. Kam, I. R. Cohen and D. Havel, "The immune system as a reactive system: modeling T cell activation with statecharts," *Proc. Sym. Human-Centric Computing Languages and Environments*, Stresa, Italy: IEEE Comp. Soc. Press, pp. 15-22, 2001.
- [18] S. Forrest and S. A. Hofmayr, "Immunology as information processing," In *Design principles for immune system & other distributed autonomous systems*, L. A. Segel and I. R. Cohen, Eds. Oxford: Oxford Univ. Press, pp.361-387, 2000.
- [19] C. Warrender, S. Forrest and L. A. Segel, "Effective feedback in the immune system," In *Genetic and evolutionary computation conference workshop*, S. Morgan and H. Kaufmann, Eds., pp.329-332, 2001.
- [20] D. J. Smith, S. Forrest, D. H. Ackley and A. S. Perelson, "Using lazy evaluation to stimulate realistic-size repertoires in models of the immune system," *Bull. Math. Biol.*, in press.
- [21] R. Virchow, *Zellulopathologie*. Leipzig: S Hirzel, 1868.
- [22] L. G. Lajtha, "Proliferation kinetics and steady state cell populations," In *Control of cellular growth in adult organisms*, H. Teir and T. Rytömaa, Eds. London: Academic Press, pp.97-105, 1967.
- [23] T. Rytömaa and K. Kiviniemi, "Regulation system of blood cell production," In *Control of cellular growth in adult organisms*, H. Teir and T. Rytömaa, Eds. London: Academic Press, pp. 106-138, 1967.
- [24] J. F. Duplan, "Control of the regeneration of haematopoietic tissues in irradiated mice," In *Control of cellular growth in adult organisms*, H. Teir and T. Rytömaa, Eds., London: Academic Press, pp.182-200, 1967.

- [25] E. P. Hochberg, A. C. Chillemi, C. J. Wu, D. Neuberger, C. Canning, K. Hartman, E. P. Alyea, R. J. Soiffer, S. A. Kalams and J. Ritz, "Quantitation of T-cell neogenesis in vivo after allogeneic bone marrow transplantation in adults," *Blood*, vol. 98, pp. 1116-1121, 2001.
- [26] P. Schlenke, S. Sheikhzadeh, K. Weber, T. Wagner and H. Kirchner, "Immune reconstitution and production of intracellular cytokines in T lymphocyte populations following autologous peripheral blood stem cell transplantation," *Bone Marrow Transpl.*, vol. 28, pp. 251-257, 2001.
- [27] Y. Modigliani, G. Coutinho, O. Burlen-Defranoux, A. Coutinho and A. Bandeira, "Differential contribution of thymic outputs and peripheral expansion in the development of peripheral T cell pools," *Eur J. Immunol.*, vol. 24, pp. 1223-1227, 1994.
- [28] D. C. Douek, R. D. McFarland, P. H. Keiser, E. A. Gage, J. M. Massey, B. F. Haynes, M. A. Polis, A. T. Haase, M. B. Feinberg, J. L. Sullivan, B. D. Jamieson, J. A. Zack and R. A. Koup, "Changes in thymic function with age during the treatment of HIV infection," *Nature*, vol. 396, pp. 690-695, 1998.
- [29] B. D. Jamieson, D. C. Douek, S. Killian, L. E. Hultin, D. D. Scripture-Adams, J. V. Giorgi, D. Marelli, R. A. Koup and J. A. Zack, "Generation of functional thymocytes in the human adult," *Immunology*, vol. 10, pp. 569-575, 1999.
- [30] C. Tanchot and B. Rocha, "The peripheral T cell repertoire: independent homeostatic regulation of virgin and activated CD8⁺ T cell pools," *Eur. J. Immunol.*, vol. 25, pp. 2127-2136, 1995.
- [31] C. Tanchot and B. Rocha, "Peripheral selection of T cell repertoires: The role of continuous thymic output," *J. Exp. Med.*, vol. 186, pp. 1099-1106, 1997.
- [32] M. J. Gabor MJ, R. Scollay and D. I. Godfrey, "Thymic T cell export is not influenced by the peripheral T cell pool," *Eur. J. Immunol.*, vol. 27, pp. 2986-2993, 1997.
- [33] F. F. Fagnoni, L. Lozza, C. Zibera, A. Zambelli, L. Ponchio, N. Gibelli, B. Oliviero, L. Pavesi, R. Gennari, R. Vescovini, P. Sansoni, G. da Prada and G. Robustelli della Cuna, "T-cell dynamics after high-dose chemotherapy in adults: elucidation of the elusive CD8⁺ subset reveals multiple

homeostatic T-cell compartments with distinct implications for immune competence," *Immunology*, vol. 106, pp. 27-37, 2002.

- [34] A. W. Goldrath and M. J. Bevan, "Selecting and maintaining a diverse T-cell repertoire," *Nature*, vol. 402, pp. 255-262, 1999.

TABLE I

Base model parameters for simulating normal T cell pools across the lifespan of a typical normal individual used in (2) and Fig. 3.

$w(t_0) = 100.0$	$x(t_0) = 1.0 \times 10^4$	$y(t_0) = 1.0 \times 10^7$	$z(t_0) = 1.0 \times 10^5$
$\mu_w = 50.0$	$\mu_x = 25.0$	$\mu_y = 2.5 \times 10^6$	$\mu_z = 1.0 \times 10^4$
$\sum(P_w - D_w - I_w) = -0.531$	$a = 5.0 \times 10^{-7}$	$b = 2.0 \times 10^{-7}$	$c = 5.0 \times 10^{-7}$
$\sum(P_x - D_x - I_x) = -0.04$	$d = -5.5 \times 10^{-8}$	$e = 3.6 \times 10^{-7}$	$f = 5.0 \times 10^{-7}$
$\sum(P_y - D_y - I_y) = -0.7$	$g = 1.0 \times 10^{-7}$	$u = 0.05$	$\delta = 0.001$
$\sum(P_z - D_z - I_z) = -0.023$			

Pool values were downsized exponentially while keeping the inter-pool relationships in order to keep computational working times within realistic limits; for the same reason initial pool values at t_0 were adjusted from the textbook values of $w = 1 \times 10^5$; $x = 2.0 \times 10^7$; $y = 4.5 \times 10^{11}$ and $z = 8.0 \times 10^9$.

TABLE II

Ranges and sensitivities of virtual values for the “connection strengths” among pools, i.e. for combined feedback and feedforward mechanisms.

Parameter	Function	Low Range Value	High Range Value	Relative Sensitivity
a	feedback $x \rightarrow w$	-2.0×10^{-6}	3.0×10^{-6}	Low
b	feedback $y \rightarrow w$	2.0×10^{-7}	4.0×10^{-7}	Med
c	feedback $z \rightarrow w$	-6.0×10^{-7}	5.0×10^{-7}	Low
d	feedback $y \rightarrow x$	0.55×10^{-7}	0.65×10^{-7}	High
e	feedback $z \rightarrow x$	3.4×10^{-7}	3.8×10^{-7}	High
f	feedforward $w \rightarrow x$	-2.0×10^{-6}	2.0×10^{-6}	Low
g	feedback $z \rightarrow y$	0.7×10^{-7}	1.8×10^{-7}	Med
u	feedforward $x \rightarrow y$	-2.0	10.0	Low
δ	feedforward $y \rightarrow z$	0.0005	0.0012	Med
$\mu(w)$	regeneratory potential (w)	40.0	80.0	Med
$\mu(x)$	regeneratory potential (x)	-10.0	5.0×10^4	Low
$\mu(y)$	regeneratory potential (y)	2.3×10^6	2.7×10^6	High
$\mu(z)$	regeneratory potential (z)	0.7×10^4	1.1×10^4	High
$P_w - D_w - I_w$	self-feedback (w)	-1.0	-0.3	Low
$P_x - D_x - I_x$	self-feedback (x)	-0.07	-0.03	Med
$P_y - D_y - I_y$	self-feedback (y)	-0.75	-0.65	High
$P_z - D_z - I_z$	self-feedback (z)	-0.025	-0.022	High

Figure Captions

Fig. 1. Basic steps in T cell maturation and microenvironmental influences: stem cells from the bone marrow enter and move through the thymus, where they expand and undergo maturation and selection under the influence of factors from epithelial cells, macrophages and antigen presenting cells. They leave the thymus into the periphery (blood and lymphoid tissues) as mature virgin lymphocytes (FHC: fibrohistiocyte; MPH: macrophage; CEC: cortical epithelial cell; MEC: medullary epithelial cell; APC: antigen presenting cell).

Fig. 2. Simplified block diagram of computer model with individual maturation steps of T lymphocytes under feedforward and feedback control. Selective cell markers identified in the individual cell pools are used in a way that they can also be determined in the peripheral blood where these cells are indicative of their activities in individual pools. (Note: in the practical approach, additional markers are applied for differential diagnosis of cells).

Fig. 3. Computer simulation of normative data over a typical normal person's lifespan (birth to 80 years). Shown are relative cell counts vs. time for cell pools in bone marrow (w : stem cells), thymic cortex and medulla (x , y), and peripheral total T cells (z). Absolute cell counts are normalized so as to fit all four curves into a single plot.

Fig. 4. Exemplary computational simulation of the ranges of virtual values of feedback responses from thymic cortex to bone marrow (see Table II, factor a). Shown are the cell changes in compartments bone marrow (top left), thymic cortex (top right), thymic medulla (bottom left) and periphery (bottom right). Black are normal medium values, colored are upper and lower ranges. Physiologic deviations in the bone marrow under these conditions do not cause alterations in the other cell pools (only one cell curve indicates overlapping of values for upper and lower ranges).

Fig. 5. Exemplary computational simulations of the ranges of virtual values of feedback responses from the periphery to the thymic medullary pool (see Table II, factor g). Cell pools are the same as shown in Fig. 4.

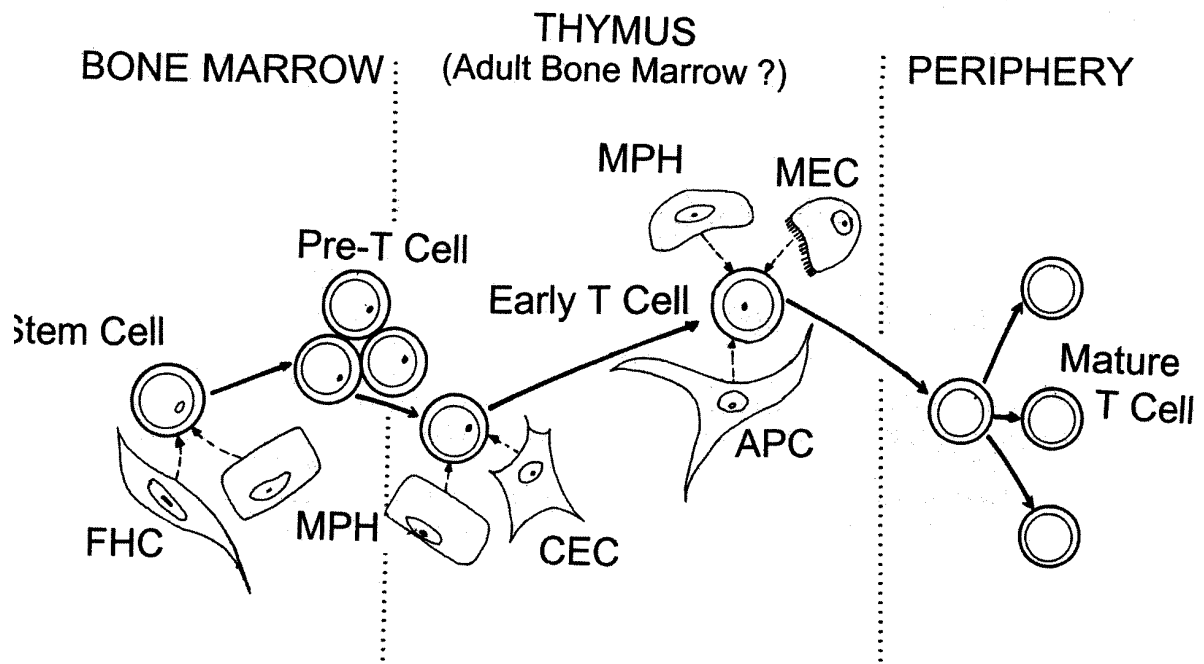

Figure 1. Brandt et al.

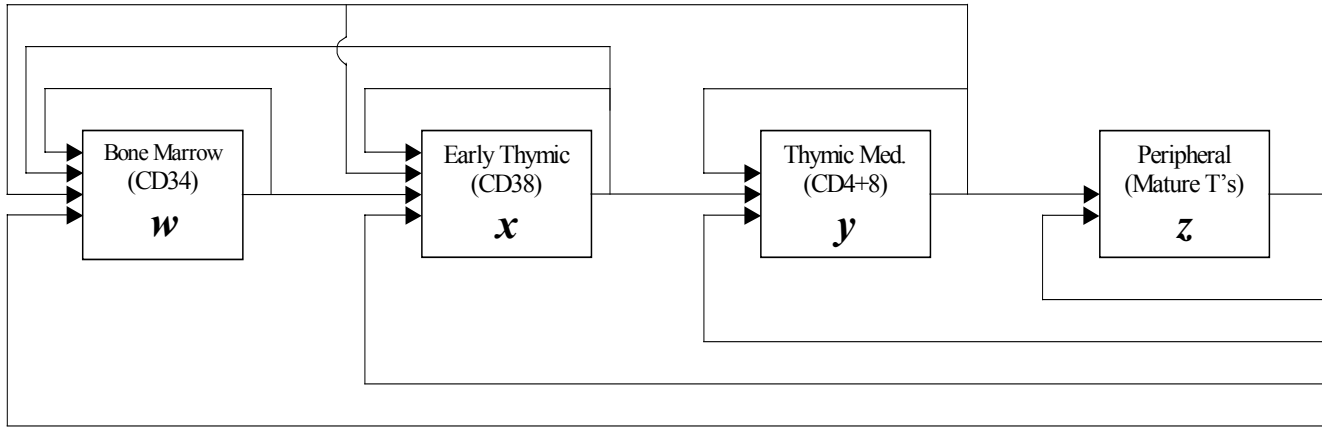

Figure 2. Brandt et al.

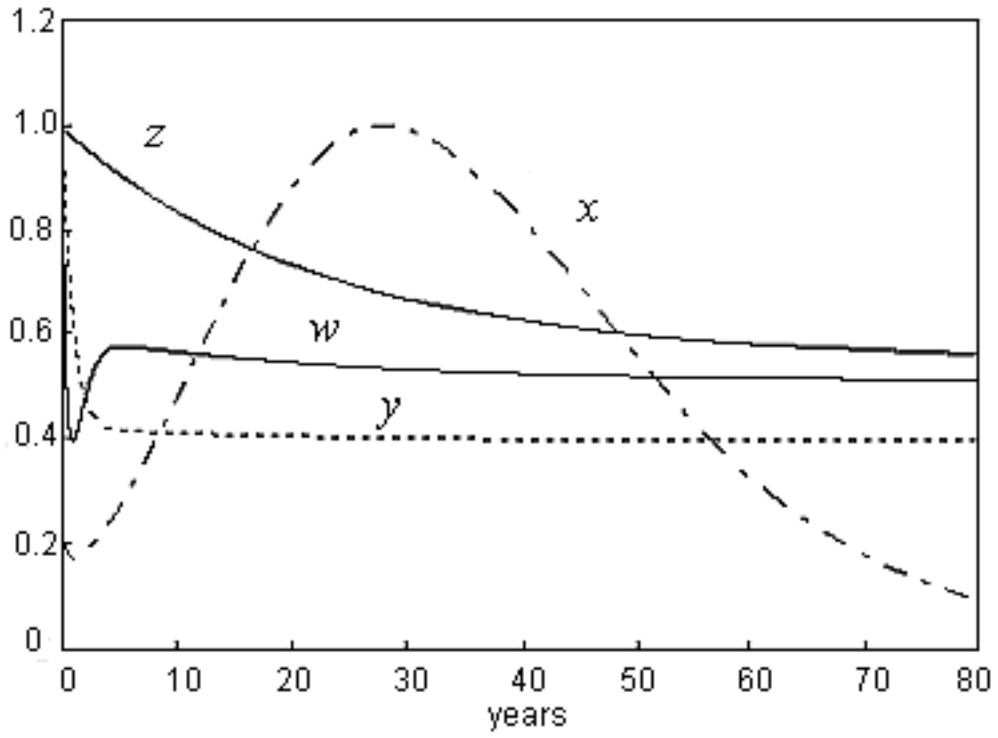

Fig. 3. Brandt et al.

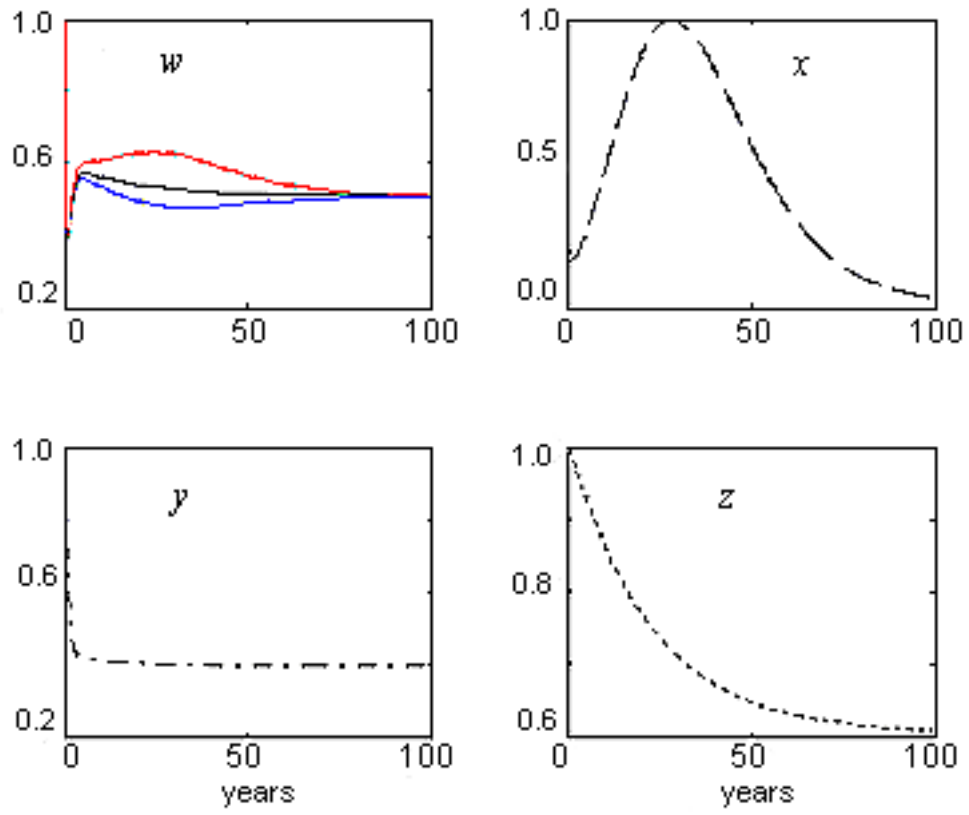

Figure 4. Brandt et al.

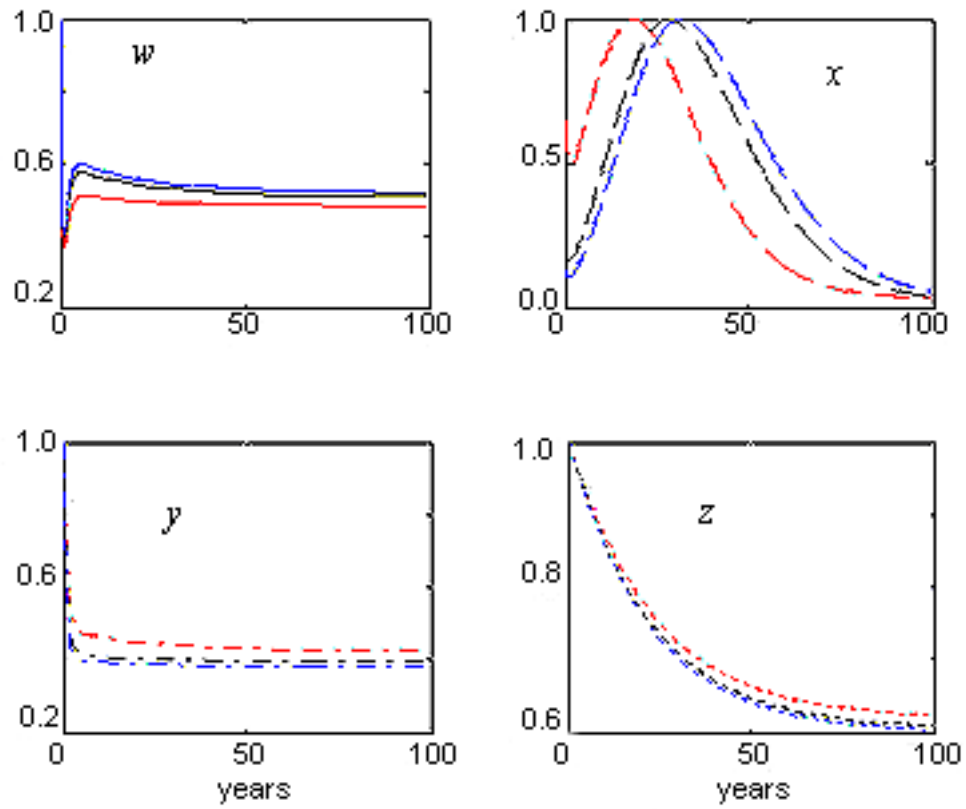

Figure 5. Brandt et al.